

Exergy Evaluation and Optimization of a New Steam Power Plant Configuration in order to Use the Boiler Blowdown Water

Majid Sabzpooshani ^{1,2,*}, Erfan Azadehfar ² and Shokoufeh Sardarian ²

¹ Faculty of Mechanical Engineering, University of Kashan, Kashan, Iran

² Energy Research Institute, University of Kashan, Kashan, Iran

*Corresponding author: spooshan@kashanu.ac.ir

Manuscript received 22 April, 2018; Revised 8 February, 2019; accepted 18 February, 2019. Paper no. JEMT-1804-1084.

The considerable growth of energy demand and limitation of fossil fuels have propelled researchers to try finding a suitable solution to preserve these resources. Some water in the boiler drum is drained to prevent corrosion and erosion of turbine fins, which is called blowdown, causes energy loss in power plant. This research was conducted energy and exergy analysis and exergy destruction of a sample 56 MW steam power plant in response to changes in the mass flow rate of water blowdown from the boiler. The mass flow rates of water blowdown are considered between 1-10% of the mass flow rate, which passes from the boiler toward the low-pressure heat exchangers called LPH4 and LPH5. The major centers of irreversibility were identified. The results indicated that elevating the turbine input temperature by 100 K resulted in about 11% increase in the turbine exergy efficiency. On the other hand, with the elevation of the condenser pressure by 0.9 MPa, the condenser exergy efficiency diminished by 0.6%. The results also showed that when using a flash tank in the exchangers, the plant had a better status and greater exergy efficiency especially in case of considering water blowdown. The results revealed that in the LPH5, increasing of water blowdown decreases exergy efficiency, while in another exchanger (LPH4) it led to increase exergy efficiency. The maximum exergy efficiency of the cycle was obtained about 32.13% and associated with 10% water blowdown from the boiler toward the LPH4 exchanger.

Keywords: Steam Power Plant, Energy Saving, Exergy Efficiency, Flash Tank, Blowdown Water.

<http://dx.doi.org/10.22109/jemt.2019.128131.1084>

Nomenclature

ex	Exergy per mass unit (kJ/kg)
E	Flow energy (kJ/s)
\dot{Q}	Heat transfer (kJ/s)
$\dot{i}_{destroyed}$	Irreversibility (kJ/s)
\dot{m}	Mass flow rate (kg/s)
$\dot{E}x$	Rate of exergy (MW)
h	Specific enthalpy (kJ/kg)
s	Specific entropy (kJ/kg K)
T	Temperature (°C)
\dot{W}	Power (kW)

Subscripts

a	Air
B	Blowdown
D	
ch	Chemical
f	Fluel

g	Gravity force
i	Inlet
k	Kinetic
y_i	Molar fraction
n	Number of fuel mols
O	Outlet
Ph	Physical
P	Potential
ref	Refrence
z	The flow altitude above sea level
0	Dead state point

1. Introduction

Energy supply resources including oil, gas, and coal are progressively depleting around the world. Therefore, new approaches are needed for optimal using of fossil fuels resources. With regard to the special status of steam power plants, researchers are working to improve the efficiency of these power plants by several methods such as improving the processes and examining irreversible factors and then, finding solutions to reduce energy losses [1-4]. Typically,

performance of thermal power plants is evaluated by using of the first law of thermodynamics or energy efficiency because it does not differentiate between the quality and quantity of energy. However, in recent years the exergy performance based on the second law of thermodynamics has found as useful method for design, evaluation, optimization and improvement of thermal power plants. The exergy performance analysis can not only specify magnitudes, location and causes of irreversibility in the power plants, but also obtains more meaningful assessment of power plant for individual components efficiency. Thus, exergy analysis indicates a realistic view of the performance of equipment and is considered a useful tool for engineering assessment [5-10]. Exergy analysis is like a key for better understanding processes in terms of quality and quantity. This understanding can only be realized by specifying quality of energy in each equipment [11-12]. Although exergy performance analysis cannot determine the irreversibility factors in a power plant, but it offers a suitable estimation for the efficiency of every equipment. Exergy efficiency evaluation of each equipment which used in power plants with using of the exergy equations can be examined the equipment of the power plant that have no suitable performance [13-14]. One of the parts that typically causes energy loss in power plants is exit of part of water passed from boiler that called blowdown water to prevent corrosion and erosion of turbine fins. One of the methods, which can be used to enhance the performance of power plant, is use of this water blowdown from boiler. As the output water of boiler does not have a considerable temperature and pressure, it can be used in heat exchangers for preheating processes. Many researches have been done concerning energy and exergy performance with regards to thermal power plants. For instance, Sciubba and Su [15] used second law analysis in a power cycle of steam turbine. They studied the effect of temperature, reheating pressure, and number of reheating of feed water on improving cycle performance. Their results indicated that between the power plant equipment, the greatest exergy destruction occurs in the boiler and then condenser. Fischer [16] employed energy and exergy analyses to determine inefficient equipment of the system. By analyzing and identifying this equipment, he was able to enhance the cycle efficiency. Dincer and Al-Muslim [17] studied power plant cycle with reheating processes. They analyzed Rankin cycle and assess the effect of different parameters including boiler temperature, boiler pressure, and mass fraction ratio on the output power and performance of the plant. They identified the processes that caused the system inefficiency. Rosen and Tang [18] done energy and exergy performance evaluation for a sample steam power plant. They found that generator had the greatest inefficiency among the other equipment, and thus by reducing irreversibility in this equipment, elevation of plant efficiency is possible. Erdem et. al. [19] analyzed the performance of several thermal power plants under control governmental bodies in Turkey, from energy and exergy viewpoint. They identified the main sources of thermodynamic inefficiencies as well as reasonable comparison of each plant to others. Aljundi [20] examined energy and exergy performance of each equipment in steam power plant in Jordan and calculated the energy and exergy losses of equipment. They found that the maximum exergy destruction occurs in the boiler, turbine, and condenser respectively. In addition, they investigated the effect of ambient temperature on exergy cycle performance. Sengupta et. al. [21] used exergy analysis for a 210-MW thermal power plants based on coal fuel in India. They calculated exergy efficiency of the plant at different conditions, such as different loads, different condenser pressures, with and without regenerative heaters and with different settings of the turbine governing. They observed that with elevation of the pressure behind the condenser, exergy destruction also increased. Further, the higher the nominal load of the power plant, caused the greater the power plant efficiency. Regulagadda et al. [22] applied energy and exergy point of view to analyze a subcritical boiler-turbine generator for a 32 MW coal-fired power

plant. They concluded that exergy loss distribution of the boiler and also turbine irreversibility yield the highest exergy losses in the power plant. Elhelw et al. [23] compared relation between power plant exergy and thermal efficiencies for two different loads. They showed that with the exergy analysis, the maximum source of exergy destruction occurs in the boiler, followed by the turbine and then the condenser. They demonstrated when superheat steam temperature inlets to HPT increased, the power at both full load and half load saved. Ganapathy et al. [24] investigated energy and exergy loss of equipment in a 50-MW thermal power plant in India. They reported that maximum energy loss occurred in the condenser, while the highest exergy loss was observed in the boiler. Zhao et al. [25] demonstrated an exergy analysis of the turbine system in a 1000MW double reheat ultra-supercritical power plant. They found that irreversibilities yield the highest exergy loss in the turbine. Also, they declared that the exergy losses of the turbine and condenser in the double reheat system were less than the single reheat system. Reddy and Mohamed [26] examined exergy analysis of a natural gas fired combined cycle power generation unit to investigate the effect of gas turbine inlet temperature and pressure ratio on exergetic efficiency for the plant and exergy destruction for the components. By considering the constant input temperature of the turbine, they calculated optimal pressure ratio in the turbine. Srinivas [27] analyzed combined cycle with methane fuel using first and second laws of thermodynamics. Their results suggested that optimal input temperature of turbine is about 1400°C. Eke et al. [28] evaluated the energy and exergy performances of each component of sample power plant in Nigeria. Their results illustrated that with variation of the environmental temperature, there were no significant changes in the values of exergy efficiency of the boiler/steam generator. Bahadori and Vuthaluru [29] suggested a new method to calculate heat recovery level from boiler blowdown. They presented a simple-to-use predictive tool with fewer computations to arrive at an appropriate estimation of the percent of blowdown that is flashed to steam as a function of flash drum pressure and operating boiler drum pressure followed by the calculation of the amount of heat recoverable from the condensate. However, they didn't argue on the exergetic performance of power plant. Noroozian et al. [30] analyzed a steam power plant and suggested reverse osmosis (RO) system, which had been designed based on recovering boiler blowdown water and cooling tower blowdown. The results indicated that using of the proposed system can enhance the total output power of the power plant. Rao [31] explored the possibility of reduction in exergy destruction by successive cooling of the dumped steam in the condenser. They increased the exergy efficiency of the power plant by this way. Khoshkar Vandani et al. [32] examined energy and exergy analysis of boiler blowdown heat recovery of a steam power plant in Iran. Their results showed that using blowdown recovery technique, the net generated power increases 0.72% and energy and exergy efficiency of the system increase. Also, the optimization results indicated that temperature and pressure of boiler outlet stream have a higher effect on the exergy efficiency of the system in respect to the other decision variables. However, they didn't investigate the effect of percentage of water blowdown and also reheating process on the power plant efficiency. The researches have shown the importance of energy and exergy analysis of power plants to improve their performance. Studies have shown, despite extensive research done so far, the performance of the power plant didn't investigate due to the change in the mass flow rate of blowdown water which drains from the boiler. Another important matter is the distribution of water blowdown between the heat exchangers of the plant to achieve maximum efficiency. In this context, the use of fuzzy inference system (FIS) method is very effective. In the current research, at first exergy destruction of each component of a sample power plant is calculated and then the exergy efficiency of the plant is computed. Then a new configuration of a steam power plant presented and evaluated for optimization of the mass flow rate of boiler blowdown water based on the exergy performance and FIS. Finally, the obtained results are

discussed and the performance improvement of the proposed power plant is evaluated and also the best case to distribute blowdown water between heat exchangers has been achieved.

2. Power plant cycle

In this section, at first a basic power plant is discussed. Then, with considering of water blowdown from the boiler, new cycles are presented and analyzed. Also, to improve the performance of power plant cycle, flash tank added to the cycles and the efficiency of cycles with flash tank investigated.

2.1. Introducing the reference cycle

The basic steam power plant cycle is demonstrated in Fig. 1. The studied cycle has been adapted from Al-Hussein power plant in Jordan with a capacity of 396 MW [20]. It's electricity plant consists of seven steam turbines along with two gas turbines at 100% of the load. According to Fig. 1, superheated vapor leaves the boiler at temperature and pressure equal to 793 K of 9.12 MPa respectively, and is conducted towards the turbine. Then the superheated vapor is divided into six blowdowns after driving the turbine. One of the blowdowns vapor stream moves towards the condenser, and after passing through cool air flow, condenses to liquid state. Two pass of the water blowdown flows towards the two high pressure heat exchangers (HPH1 and HPH2), while two other blowdowns are transferred to the low-pressure heat exchangers (LPH4 and LPH5).

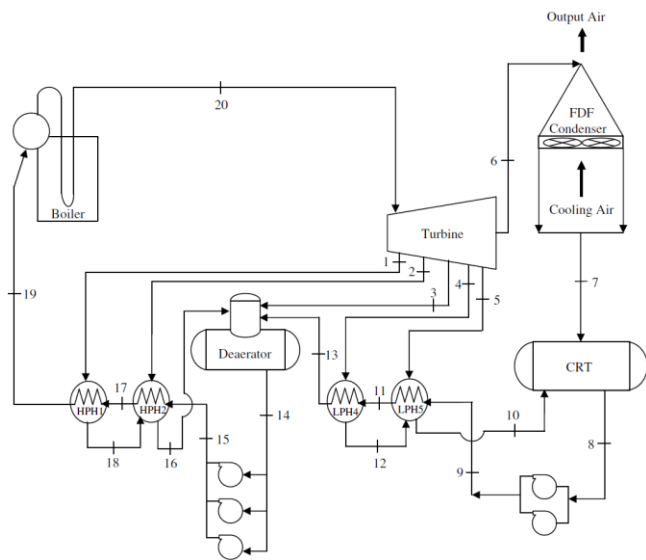

Fig. 1. Schematic diagram of the reference steam power plant [20]

Eventually, one pass of water blowdown from turbine is conducted towards deaerator. In the boiler of power plant heavy oil fuel used for combustion process. The details for this fuel are provided in Table 1. Also, the conditions for power plant operation of the are shown in Table 2.

Table 1. Specifications of the consumed fuel [20]

Property	Value
Density at 15°C	0.9705 g/mL
Kinematic viscosity at 100°C	35.52 cSt
Gross calorific value	42943.81 kJ/kg
Net calorific value	40504.58 kJ/kg

Table 2. The conditions for operating of the power plant [20]

Operating condition	Value
Mass flow rate of fuel	5.0 Kg/s
Inlet gas volumetric flow rate to burners	188,790 N m ³ /h

Stack gas temperature	411.15 K
Feed water inlet temperature to boiler	494.15 K
Steam flow rater	275 ton/h
Steam temperature	793.15 K
Steam pressure	9.12 MPa
Power output	56 MW
Power input to FDC/fan	88 KW
Number of fans	18
Mass flow rate of cooling air	23,900 ton/h
Combined pump/motor efficiency	0.95

In the base steam power plant, water blowdown from the boiler has not been considered.

2.2. Introducing the reference cycle

To prevent corrosion and erosion of turbine fins and boiler tubes, total dissolved solids (TDS) in the vapor should be lower than the allowable limit. These actions occur by introducing some chemicals into water with a closed system [37]. However, if the concentration and application of chemicals exceed the standard and allowable limit, it will cause serious problems in the operations [38]. To solve this problem, drain some water out of the boiler, which is called water blowdown. Thus, the innovation in the proposed cycle comparison to the reference cycle is using of water blowdown from the boiler in the processes power plant system according to Fig. 2.

Specific enthalpy and mass flow rate at site number 20, which is shown in Fig. 2, are heavily influenced by the output water blowdown from the boiler. This pipe line transmits water vapor which produced in the boiler to the turbine, thus reduction of specific enthalpy and mass flow rate at pipe line 20 can reduce the total work of the turbine and also cycle efficiency.

Typically, in the power plants about 4-8% of water is drain from the boiler to prevent of corrosion. However, this value can increase to 20% because of a very unfavorable quality [39]. Blowdown water from the boiler is in saturated liquid conditions, and its pressure is equal to the boiler pressure. Thus, this water has a high energy; if it is not used, a suitable heat source will be lost [40-41]. Indeed, one of the methods to enhance the performance of power plants is reuse of the boiler blowdown water. As the output water has a considerable temperature and pressure, it can be used in heat exchangers for preheating processes.

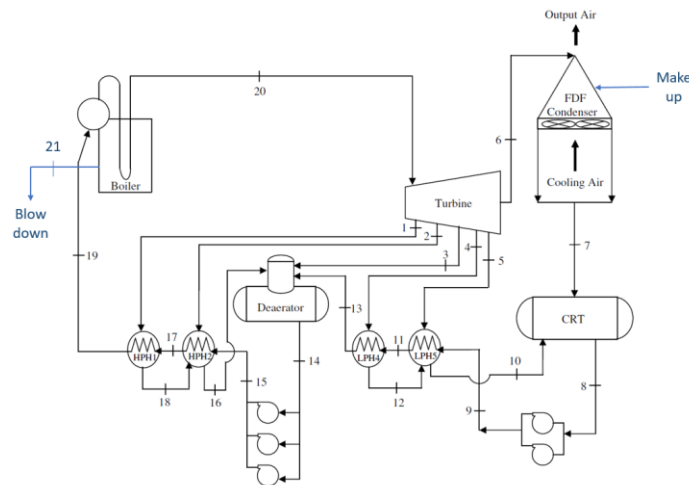

Fig. 2. Schematic diagram of the steam power plant [20] along with the boiler blowdown.

2.3. Applying flash tank system in the heat exchangers

In this study, attempts were made to implement flash tank for recovering the heat energy of the water blowdown from boiler in the thermal power plant. The amount of mass flow rate of water vapor produced in the flash tank is obtained as follow [31]:

$$\dot{m}_{flash} = \frac{h_{f,high-p} - h_{f,low-p}}{h_{fg,low-p}} * \dot{m}_{BD} \quad (1)$$

Where, $h_{f,high-p}$ is the enthalpy of the saturated liquid at the boiler working pressure, $h_{f,low-p}$ represents the enthalpy of the saturated liquid at the working pressure of the heat exchanger, and $h_{fg,low-p}$ shows the water latent heat at the heat exchanger pressure. \dot{m}_{BD} indicates the mass latent of the water blowdown from the boiler. Evidently, the flash tank system is applicable in heat exchangers, when the enthalpy of the saturated liquid at the boiler pressure is greater than the enthalpy of the saturated liquid at the heat exchanger pressure. According to Figures 3 and 4, this system can only be implemented in LPH4 or LPH5 heat exchangers separately.

In this research, two approaches are propounded to assess the performance of turbine and cycle exergy and the net power of the turbine and cycle output. Firstly, the flows resulting from the turbine blowdowns should not be changed after the output flow of flash tank (line 22 in the Fig. 3 or Fig. 4) was injected in the LPH4 or LPH5 heat exchangers. The second approach is that the flows resulting from turbine blowdowns change be up to the level of vapor leaving the flash tank. Figures 3 and 4 illustrate implementation of flash tank for LPH4 and LPH5 heat exchangers.

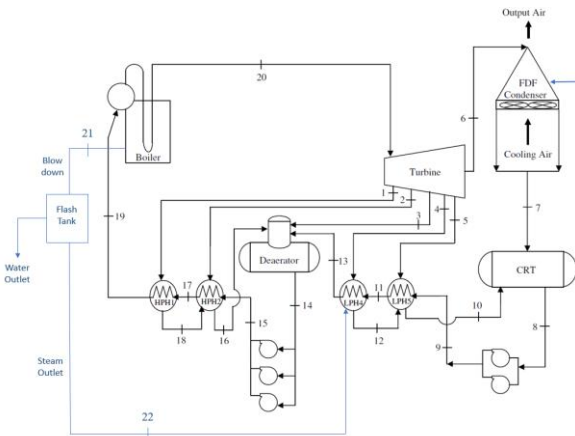

Fig. 3. Schematic diagram of steam power plant [20] with the flash tank system in LPH4

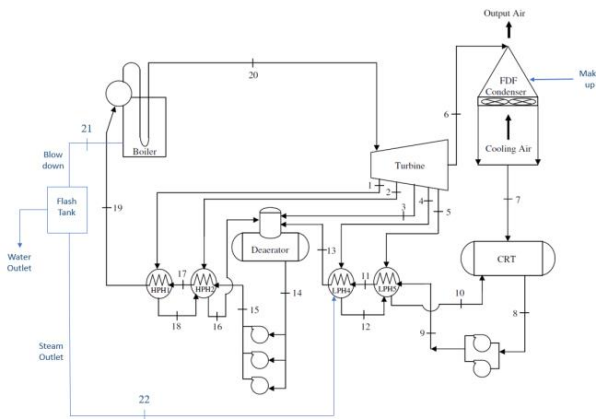

Fig. 4. Schematic diagram of steam power plant [20] with the flash tank system in LPH5

2.4. Contemporary reusing of boiler water blowdown in two heat exchangers

In the above cycles, water blowdown from the boiler injected to the exchangers separately. Now, the modeling will be performed concurrently on both exchangers and the effect of the level of blowdown water on the exergy efficiency of cycle will be evaluated. Fig. 5 represents the new mentioned cycle.

As seen from Fig. 5, water blowdown from the boiler divided in two parts. One part conducted a portion of water blowdown into the LPH4 exchanger with flash tank and line number 22 and the other conducted to the LPH5 exchanger with flash tank and line number 23.

2.5. Fuzzy inference system

Simulation of the cycle with concurrently usage of blowdown water into the LPH4 and LPH5 exchangers was performed using the fuzzy inference system (FIS). Fuzzy was introduced based on uncertainty potential. Indeed, Lotfizadeh proposed fuzzy logic as the key for solving problems for which probability theory was not capable to solve [42].

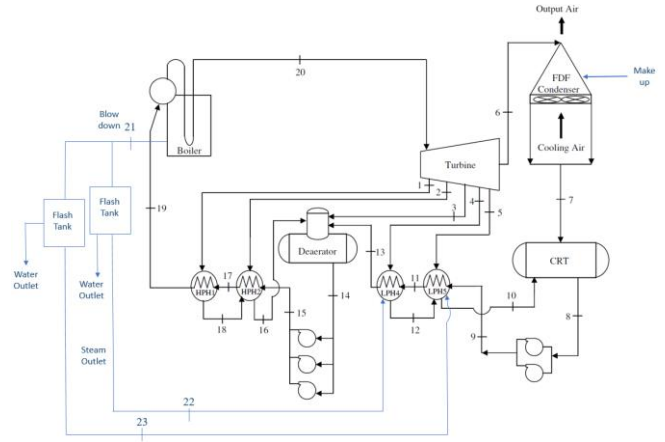

Fig. 5. A schema of the boiler Blowdown in LPH4 and LPH5 exchangers concurrently

Fig. 6 represents the fuzzy logic system, which includes two inputs (one is the percentage of the water blowdown transmitted to the LPH4 exchanger and the other into the LPH5) and one output (exergy efficiency of cycle). FIS includes a set of rules governing the problem.

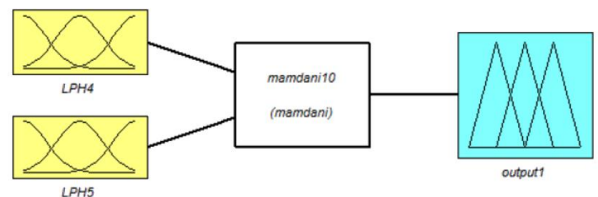

Fig. 6. The aggregation method in FIS for the steam power plant.

For each of the inputs, 10 triangular functions were considered which representing the percentage of boiler blowdown water. In each input and output, the membership degree has been specified. To represent a unique number, defuzzification methods including center of gravity or weighted mean should be used in aggregation method so that the output could be displayed as a number [42].

3. Energy and exergy analyses of steam power plants

In this section, the governing equations for the power plant cycles are presented based on continuity, energy and exergy equations.

3.1. Energy analysis

The first law of thermodynamics or energy conservation for steady-state processes and open systems is defined according to equation 2.

$$\sum \dot{m}_i h_i + \dot{Q} = \sum \dot{m}_o h_o + \dot{W} \quad (2)$$

where, \dot{Q} is the heat transfer rate to the system, and \dot{W} represents net work performed on the system.

3.2. Exergy analysis

The maximum potential of work possible for a system is called exergy. In the open flow systems, there are three types of energy transfer: work transfer, heat transfer, and mass transfer. Exergy (ΨQ) is determined as heat transfer (Q) off the control surface at the temperature of T towards the maximum work (W_{max}), according to equation 3 [33].

$$W_{max} = \Psi_Q = Q \left(1 - \frac{T_0}{T}\right) \quad (3)$$

Steady-state exergy is including the kinetic, potential, and physical exergy. Energy analysis is based on first law of thermodynamics and is related to energy conservation. Analysis of the second law is a method which is used based on mass conservation and energy quality drop along with entropy generation in analyzing the design and improvement of energy systems. The flow exergy for steady-state processes in an open system is defined as [33]:

$$\sum \left(1 - \frac{T_0}{T}\right) Q_k + \sum_{in} \dot{m} \psi_i = \psi_w + \sum_{out} \dot{m} \psi_o + \dot{I}_{destroyed} \quad (4)$$

$$\psi = \dot{m} [(h^0 - h_0^0) - T_0 (s - s_0)] \quad (5)$$

$$h^0 = h + \frac{c^2}{2} + gz \quad (6)$$

Also, exergy destruction is defined as [33]:

$$\dot{I}_{destroyed} = T_0 \dot{S}_{gen} \quad (7)$$

ψ_i and ψ_o represent the exergy of the input and output flows, respectively. ψ_w is the useful work performed or taken from the system. $\dot{I}_{destroyed}$ denotes the process irreversibility and h_0 represents the sum of enthalpy, kinetic energy, and potential energy. Also, variable c is the fluid velocity, z represents the parameter of flow altitude above sea level, and g stands for gravity force. Among the factors causing development of irreversibility are heat transfer resulting from temperature difference, mixing of fluids with different temperatures, and friction. Indeed, exergy analysis is an effective tool to identify losses resulting from irreversibility in a real state.

For steady-state flow, exergy equilibrium for a thermal system can be obtained as [34]:

$$\psi_w = \sum_{k=1}^n \left(1 - \frac{T_0}{T_k}\right) Q_k + \sum_{k=1}^r [(\dot{m} \psi)_i - (\dot{m} \psi)_o]_k - T_0 \dot{S}_{gen} \quad (8)$$

ψ_w is the useful work performed from the system. The first term on the right side of the above equation represents the total exergy

generated through the heat transfer. The second term denotes sum of the exergy changes of the fluid work, and the last term indicates the exergy losses and irreversibility in the system. Q_k is the heat transfer rate and \dot{m} shows the mass flow rate. Ψ represents the Exergy flow rate per mass unit, \dot{S}_{gen} denotes the entropy generation rate, T_0 is the ambient air temperature and T_k shows the temperature of the heat source.

3.3. Component exergy

In the absence of electric, magnetic, and nuclear forces as well as effect of superficial tension, the total exergy of the system (Ex) has four parts: physical exergy (Ex_{ph}), chemical exergy (Ex_{ch}), kinetic exergy (Ex_k), and potential exergy (Ex_p). Thus, total exergy can be computed as [33]:

$$Ex = Ex_{ph} + Ex_{ch} + Ex_p + Ex_k \quad (9)$$

Physical exergy is considered as the summation of thermal and mechanical exergy. Equation 9 and 10 indicate physical and thermal exergy, respectively [35].

$$Ex^{ph} = Ex^T + Ex^M \quad (10)$$

$$Ex^T = \dot{m} c_p [(T - T_{ref}) - T_{ref} \ln\left(\frac{T}{T_{ref}}\right)] \quad (11)$$

Chemical exergy is defined as the maximum work of a flow can be received when the fluid flow is reached into the reference temperature and pressure. It can be obtained from following equation [35]:

$$ex^{ch} = \bar{R} T_0 \ln\left(\frac{P}{P_{0,i}}\right) = \bar{R} T_0 \ln\left(\frac{1}{y_i}\right) \quad (12)$$

When the fluid flow consists of several gases (which called reactants), the chemical exergy of a mixture of gases can be found as [36]:

$$ex_{mix}^{ch} = \sum_{i=1}^n y_i ex_i^{ch} + \bar{R} T_0 \sum_{i=1}^n y_i \ln(y_i) \quad (13)$$

where, n parameter represents the number of fuel moles in the reactants, and y_i shows the molar fraction of the constituents.

Based on the above exergy equations, exergy efficiency and exergy destruction can be defined for each element and for the cycle. Table 4 indicates exergy analysis of the equipment employed in Al-Hussein steam power plant in Jordan [34].

4. Results and discussion

In this section, the obtained results are presented and discussed. At first, the calculations performed for a basic cycle and the current results compared with the results from the previous researches in order to validate of the current method. Then, the effect of different parameters on exergy efficiency and exergy destruction of the equipment and cycle are investigated. Also, the performances of the new cycles with considering of water blowdown from the boiler are presented and argued.

4.1. Fuzzy inference system

Table 3 indicates the thermodynamic conditions of the reference power plant [20] and exergy values of different points of the plant, which is specified in Fig. 1.

Table 3. The conditions for launching the power plant [20]

Point	T (K)	P (MPa)	\dot{m} (ton/h)	\dot{E}_x (MW), Present Study	\dot{E}_x (MW) [20]
1	618.55	2.4231	17.80	5.347	5.354
2	547.85	1.3244	14.92	3.886	3.892
3	463.65	0.5690	16.40	3.473	3.478
4	394.35	0.2060	13.96	2.285	2.289
5	360.45	0.0628	6.39	0.743	0.743
6	343.15	0.0272	204.90	17.09	17.083
7	339.95	0.0272	204.90	0.634	0.635
8	339.75	0.0270	226.00	0.693	0.693
9	341.15	1.3734	226.00	0.823	0.823
10	337.60	0.0245	21.10	0.058	0.058
11	356.15	0.0536	226.00	1.312	1.312
12	362.45	0.0687	13.96	0.099	0.099
13	390.15	0.1815	226.00	3.125	3.126
14	428.15	0.6867	275.00	7.206	7.202
15	430.15	12.2630	275.00	8.241	8.237
16	436.15	0.6671	32.70	0.954	0.954
17	461.45	10.7910	275.00	11.57	11.565
18	466.15	2.3544	17.80	0.747	0.748
19	494.15	10.3010	275.00	15.73	15.732
20	793.15	9.1233	275.00	109.8	109.866

As seen from this table, the computed exergies in the different location of cycle are very close to the values which are reported by [20].

In the table 4, exergy destruction and exergy efficiency of several components of the reference cycle computed and compared with [20]. The very low error values suggest accuracy of the current simulation. Fig. 7 demonstrates the proportion of exergy destruction of each equipment in the reference cycle. It is observed that combustion chamber, turbine, and condenser have exergy losses about 81%, 11%, and 8% respectively.

Table 4. Exergy destruction and exergy efficiency of several components of the reference cycle [20]

Components	Exergy destruct. (MW), (Present Study)	Exergy destruct (MW), [20]	exergy Effici. (%) (Current Study)	exergy Effici. (%) [20]	Error (%)
Boiler	120.6	120.540	43.8	43.8	0
Turbine	19.94	20.407	72.7	73.5	1
Condenser	14.87	13.738	27	26.4	2
Boiler pumps	0.220	0.220	82.5	82.5	0
CRT pump	0.331	0.331	28.2	28.2	0
HPH1	0.441	0.438	97.4	97.4	0
HPH2	0.351	0.359	97.3	97.2	0
Deaerator	0.347	0.355	95.4	95.3	0
LPH4	0.373	0.377	89.6	89.5	0
LPH5	0.295	0.295	82.3	67.3	22
Power cycle	158.8	157.059	24.6	24.8	1

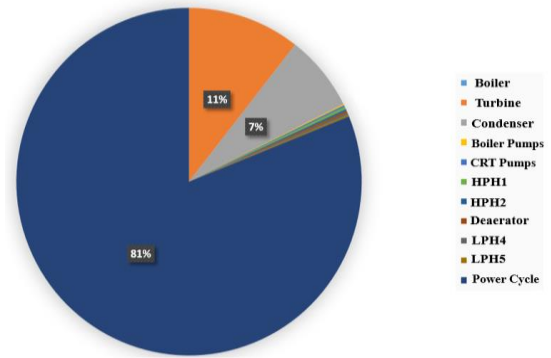

Fig. 7. The proportion of exergy destruction of each equipment in the reference cycle [20]

4.2. Effect of different thermodynamics parameters on the equipment exergy efficiency and exergy destruction for the reference cycle

In a power plant system, several design parameters exist which the variation of its can be influence on the efficiency of the power plant. In this section, the effect of different parameters such as turbine input temperature (TIT), condenser pressure and input temperature of flow at boiler on exergy efficiency and exergy destruction of components and reference cycle are investigated.

4.2.1. Effect of input temperature of the turbine (TIT)

Elevation of the input temperature flow to the turbine has a direct effect on the elevating of exergy efficiency and thus reduction of exergy destruction. As seen from Fig. 8, with increasing of turbine input temperature from 793.15 to 900 K, the turbine and cycle exergy efficiency increases from 74.1 to 85.68 % and from 25.05 to 34.37%, respectively. This is because to increase of enthalpy with rising of input temperature flow to turbine and thus the exergy of this point rises. Exergy destruction of the turbine and cycle declined from 19.94 to 12.88 and from 160.9 to 140.9 MW, respectively.

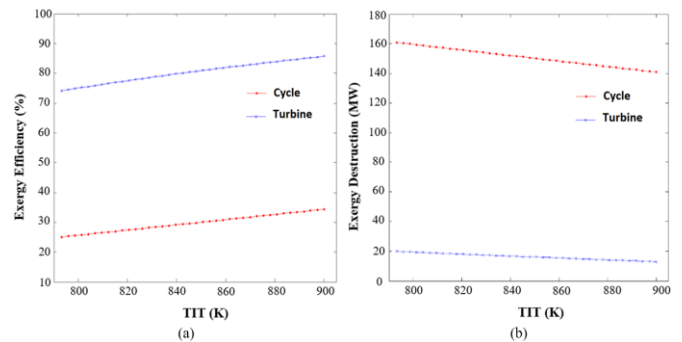

Fig. 8. Schematic diagram of the reference steam power plant [20] a) Exergy efficiency of reference cycle and turbine versus input temperature of turbine; b) Exergy destruction of reference cycle and turbine versus input temperature of turbine

4.2.2. Effect of condenser pressure

Figure 9 shows the variation of exergy efficiency and exergy destruction versus condenser pressure. It is found from this figure, with the increasing of condenser pressure from 0.0272 to 0.9 MPa, exergy destruction of condenser increases from 1.681 to 1.73 MW. Indeed, elevation of pressure causes increasing of input exergy into the condenser which has a notable effect on the incrementing exergy destruction and irreversibility. Further, with the increasing of condenser pressure, exergy efficiency of the condenser declines from

27.4 to 26.83 which shows an insignificant effect on the cycle exergy efficiency.

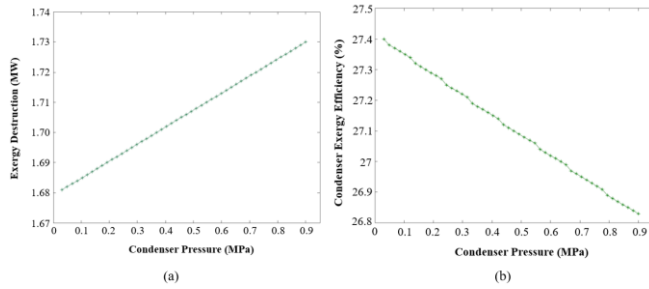

Fig. 9. a) Condenser exergy destruction and b) Condenser exergy efficiency versus the condenser pressure for the reference cycle

4.2.3. Effect of the boiler input temperature

Exergy efficiency and destruction versus boiler input temperature are shown in the Fig. 10. With the rising of the boiler input temperature from 494.2 to 585 K, exergy efficiency of the boiler decreases from 43.83 to 36.43%. On the other hand, exergy destruction of the boiler increases from 120.6 to 136.5 Mw. The effect of this parameter on exergy efficiency and exergy destruction of the cycle is very low.

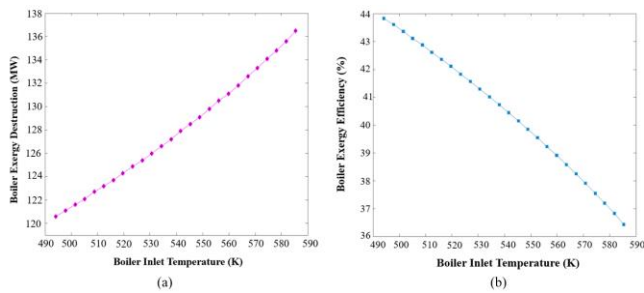

Fig. 10. a) Boiler exergy destruction and b) Boiler exergy efficiency versus boiler input temperature for reference cycle

4.3. Effect of mass flow rate of water blowdown from the boiler

In a power plant, it is possible that there is different mass flow rate of water blowdown from the boiler. Figure 11 represents the exergy performance of the cycle versus of different mass flow rate of water blowdown. In this figure, the result for five type of cycles are shown which consist of water blowdown without reuse in the cycle (Blowdown), water blowdown toward LPH4 exchanger with flash tank and without blowdown from turbine (LPH4), water blowdown toward LPH4 exchanger with flash tank and with blowdown from turbine (LPH4-m), water blowdown toward LPH5 exchanger with flash tank and without blowdown from turbine (LPH5) and water blowdown toward LPH5 exchanger with flash tank and with blowdown from turbine (LPH5-m). As expected, if the water blowdown doesn't reuse in the cycle, the exergy efficiency decreases with increasing of mass flow rate of water blowdown. As seen from Fig.11, the exergy efficiency of the cycle types LPH4-m and LPH5-m decreases dramatically with increasing of mass flow rate water blowdown from the boiler. However, if there is no blowdown from turbine (LPH4 and LPH5), the performance of cycle is better than with turbine blowdown. Also, Fig. 11 shows that the exergy efficiency increases with rising of water blowdown from the boiler in the cycle LPH4. Comparison of the two states of use of flash tank in LPH4 and LPH5 without turbine blowdown is important. Less than 3% of water blowdown from the boiler, LPH5

has a better performance in comparison to LPH4, but greater than 3% of water blowdown, LPH4 finds a better performance.

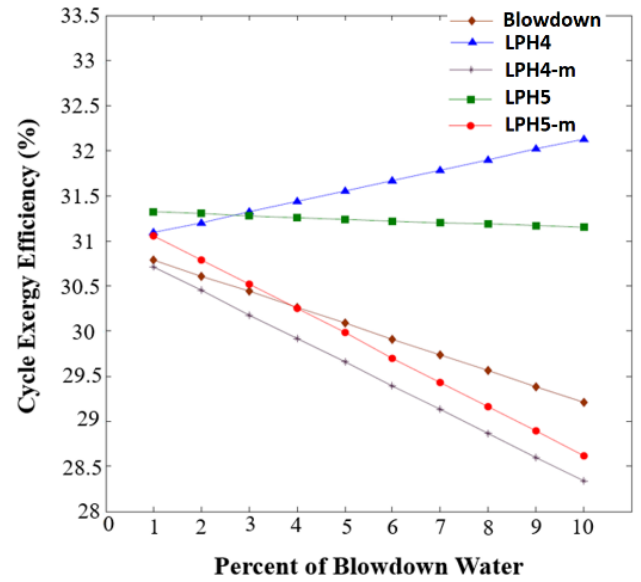

Fig. 11. Exergy efficiency of the cycle versus the percentage of the boiler Blowdown water

Table 5 provides the values of turbine and cycle exergy efficiency as well as total work of the cycles and turbine in each of the different cycles.

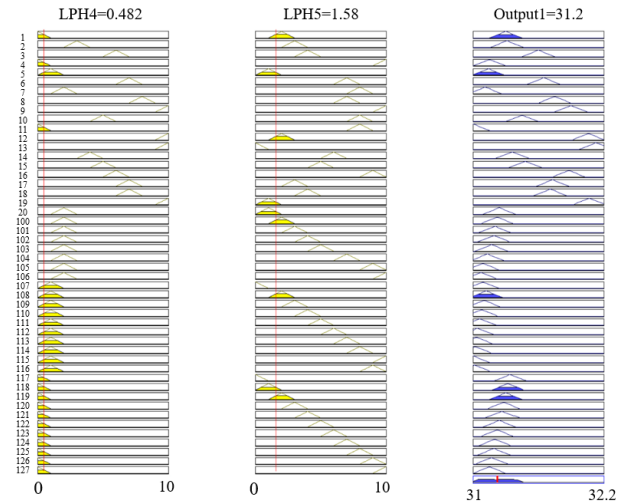

Fig. 12. The aggregation method in FIS for the steam power plant.

According to the obtained results, reusing of the boiler water blowdown without considering turbine blowdown had better and more suitable type of cycle.

4.4. Investigation of contemporary reusing of boiler water blowdown in two heat exchangers with FIS method

With respect to the amount of boiler water blowdown entering the heat exchangers can be changed, it is therefore necessary to examine the exergy efficiency of the cycle with respect to the variable flow of input to the exchangers. Figure 12 reveals the aggregation method in the fuzzy logic and Fig. 13 demonstrates the

exergy efficiency of the cycle in terms of different values of boiler water blowdown in the LPH4 and LPH5 exchangers.

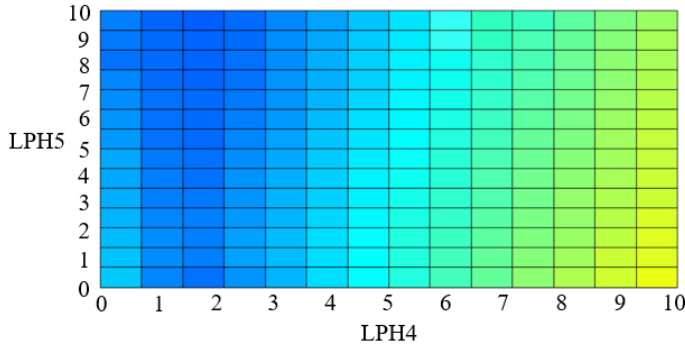

Fig. 13. Exergy efficiency of the cycle in terms of different values of Blowdown in LPH4 and LPH5 exchangers concurrently

In Fig. 13, the yellow colour area represents the maximum exergy efficiency of the power plant cycle. As the color moves towards blue, the cycle exergy efficiency decreases. It can be seen from this figure, if the blowdown water mass flow rate is constant in the LPH4, the exergy efficiency cycle declines with the increasing of the blowdown water mass flow rate in the LPH5. Also, if the blowdown water mass flow rate is constant in the LPH5, the exergy efficiency cycle increases with the increasing of the blowdown water mass flow rate in the LPH4. However, Fig. 13 specified that the maximum cycle exergy efficiency for the 10% water blowdown from the boiler can be achieved if all blowdown mass flow is sent to the LPH4 heat exchanger.

5. Conclusion

This paper proposed and evaluated a new modification for a steam power plant based on reusing of water blowdown from boiler. At first, it is investigated the effect of different parameters including the input temperature to the turbine, the temperature to the boiler, and the effect of condenser pressure on the exergy efficiency and exergy destruction of equipment and cycle. Further, the effect of flash tank system and water boiler blowdown was examined on the turbine work and total work of the cycle as well as the turbine and cycle efficiency. The results indicated that elevation of the turbine input temperature by 100 K led to about 11% increase in exergy efficiency of the turbine. On the other hand, with elevation of the condenser pressure by 0.9 MPa, exergy efficiency of the condenser declined by about 0.6%. Also, elevation of the boiler input temperature by 90 K caused 9% reduction in the boiler exergy efficiency. According to the results obtained from applying flash tank system and water boiler blowdown in the cycle, the best efficiency was achieved in the flash tank system without turbine blowdown in LPH4 exchanger. In contrast, usage of flash tank system with turbine blowdown in LPH4 exchanger brought about the minimum exergy efficiency. The results obtained from FIS method indicated that with constancy of water blowdown in LPH4 exchanger as the water blowdown mass flow rate increases in the LPH5, exergy efficiency of the cycle declines. Also, if the blowdown water mass flow rate is constant in the LPH5, the exergy efficiency cycle increases with the increasing of the blowdown water mass flow rate in the LPH4. However, the current results specified that the maximum cycle exergy efficiency for the 10% water blowdown from the boiler can be achieved if all blowdown mass flow is sent to the LPH4 heat exchanger.

Table 5. The effect of changing the percentage of the boiler blowdown on the exergy performance of the cycle across all states

Percent of BD Water	Cycle Net Power (MW)					Turbine Net Power (MW)					Cycle Exergy Efficiency (%)					Turbine Exergy Efficiency (%)				
	BD	LPH4	LPH5	LPH4-m	LPH5-m	BD	LPH4	LPH5	LPH4-m	LPH5-m	BD	LPH4	LPH5	LPH4-m	LPH5-m	BD	LPH4	LPH5	LPH4-m	LPH5-m
1%	66.1	66.74	67.23	65.93	66.68	69.42	69.81	67.23	69	66.68	30.79	31.09	31.32	30.71	31.06	81.76	81.83	82.09	81.3	81.78
2%	65.74	66.99	67.19	65.36	66.1	69.06	70.08	67.19	68.45	66.1	30.61	31.2	31.3	30.45	30.79	81.57	81.97	82.08	80.91	81.44
3%	65.34	67.24	67.15	64.8	65.52	68.7	70.34	67.15	67.9	65.52	30.44	31.32	31.28	30.18	30.52	81.37	82.11	82.07	80.53	81.11
4%	64.97	67.49	67.11	64.23	64.94	68.34	70.61	67.11	67.35	64.94	30.26	31.44	31.26	29.92	30.25	81.17	82.26	82.05	80.13	80.77
5%	64.59	67.74	67.07	63.67	64.35	67.98	70.87	67.07	66.8	64.35	30.09	31.55	31.24	29.66	29.98	80.96	82.4	82.04	79.74	80.43
6%	64.21	67.98	67.03	63.1	63.77	67.62	71.14	67.03	66.25	63.77	29.91	31.67	31.22	29.39	29.7	80.76	82.54	82.03	79.34	80.08
7%	63.84	68.23	66.99	62.53	63.19	67.26	71.4	66.99	65.7	63.19	29.74	31.78	31.2	29.13	29.43	80.56	82.68	82.01	78.93	79.73
8%	63.46	68.48	66.95	61.97	62.6	66.9	71.67	66.95	65.15	62.6	29.56	31.9	31.19	28.87	29.16	80.35	82.82	82	78.53	79.37
9%	63.08	68.73	66.91	61.4	62.02	66.55	71.94	66.91	64.6	62.02	29.38	32.02	31.17	28.6	28.89	80.14	82.96	81.99	78.12	79.02
10%	62.7	68.98	66.87	60.84	61.43	66.19	72.21	66.87	64.05	61.43	29.21	32.13	31.15	28.34	28.62	79.93	83.1	81.97	77.71	78.66

Acknowledgement

The authors would like to express their great appreciation to the Energy Research Institute of the University of Kashan for supporting this research (Grant No. 348725/3).

References

- [1] Sama, D. A. "The use of the second law of thermodynamics in process design." *Journal of Energy Resources Technology* 117, no. 3 (1995): 179-185.
- [2] Li, H., X. Zhang, L. Liu, R. Zeng, and G. Zhang. "Exergy and environmental assessments of a novel trigeneration system taking biomass and solar energy as co-feeds." *Applied Thermal Engineering* 104 (2016): 697-706.
- [3] Ellabban, O., H. Abu-Rub, and F. Blaabjerg. "Renewable energy resources: Current status, future prospects and their enabling technology." *Renewable and Sustainable Energy Reviews* 39 (2014): 748-764.
- [4] Gholamian, E., S. M. S. Mahmoudi, and V. Zare. "Proposal, exergy analysis and optimization of a new biomass-based cogeneration system." *Applied Thermal Engineering* 93 (2016): 223-235.
- [5] Utlu, Z., and A. Hepbasli. "A review on analyzing and evaluating the energy utilization efficiency of countries." *Renewable and Sustainable energy reviews* 11, no. 1 (2007): 1-29.
- [6] Bejan, A.. "Fundamentals of exergy analysis, entropy generation minimization, and the generation of flow architecture." *International journal of energy research* 26, no. 7 (2002).
- [7] Rosen, M. A., and I. Dincer. "Exergy as the confluence of energy, environment and sustainable development." *Exergy, an International journal* 1, no. 1 (2001): 3-13.
- [8] Rosen, M. A., and I. Dincer. "Exergy as the confluence of energy, environment and sustainable development." *Exergy, an International journal* 1, no. 1 (2001): 3-13
- [9] Kaushik, S. C., and O. K. Singh. "Estimation of chemical exergy of solid, liquid and gaseous fuels used in thermal power plants." *Journal of Thermal Analysis and Calorimetry* 115, no. 1 (2014): 903-908.
- [10] Kotas, T. J.. *The exergy method of thermal plant analysis*. Elsevier, 2013.
- [11] Ghazi, M., P. Ahmadi, A. F. Sotoodeh, and A. Taherkhani. "Modeling and thermo-economic optimization of heat recovery heat exchangers using a multimodal genetic algorithm." *Energy Conversion and Management* 58 (2012): 149-156.
- [12] Gong, M., and S. Werner. "Exergy analysis of network temperature levels in Swedish and Danish district heating systems." *Renewable energy* 84 (2015): 106-113.
- [13] Ostrovski, O., and G. Zhang. "Energy and exergy analyses of direct ironsmelting processes." *Energy* 30, no. 15 (2005): 2772-2783.
- [14] Ameri, M., P. Ahmadi, and Khanmohammadi, S. (2008). Exergy analysis of a 420 MW combined cycle power plant. *International Journal of Energy Research*, 32(2), 175-183.
- [15] Sciubba, E., and T. M. Su. "Second law analysis of the steam turbine power cycle: a parametric study." *Computer-Aided Engineering Of Energy Systems* 2 (1986): 3.
- [16] Fischer, D. W., and J. Katzel. "Searching for steam system efficiency." *Plant Engineering* 50, no. 13 (1996): 64-67.
- [17] Dincer, I., and H. Al-Muslim. "Thermodynamic analysis of reheat cycle steam power plants." *International Journal of Energy research* 25, no. 8 (2001): 727-739.
- [18] Rosen, M. A., and R. Tang. "Effect of altering combustion air flow on a steam power plant: Energy and exergy analysis." *International journal of energy research* 31, no. 3 (2007): 219-231.
- [19] Erdem, H. H., A. V. Akkaya, B. Cetin, A. Dagdas, S. Hakan Sevilgen, B. Sahin, I. Teke, C. Gungor, and S. Atas. "Comparative energetic and exergetic performance analyses for coal-fired thermal power plants in Turkey." *International Journal of Thermal Sciences* 48, no. 11 (2009): 2179-2186.
- [20] Aljundi, I. H. "Energy and exergy analysis of a steam power plant in Jordan." *Applied thermal engineering* 29, no. 2-3 (2009): 324-328.
- [21] Sengupta, S., A. Datta, and S. Dutttagupta. "Exergy analysis of a coal-based 210 MW thermal power plant." *International Journal of Energy Research* 31, no. 1 (2007): 14-28.
- [22] Regulagadda, P., I. Dincer, and G. F. Naterer. "Exergy analysis of a thermal power plant with measured boiler and turbine losses." *Applied Thermal Engineering* 30, no. 8-9 (2010): 970-976.
- [23] Elhelw, M., K. Dahma, and A. Attia. "Utilizing exergy analysis in studying the performance of steam power plant at two different operation mode." *Applied Thermal Engineering* 150 (2019): 285-293.
- [24] Ganapathy, T., N. Alagumurthi, R. P. Gakkhar, and K. Murugesan. "Exergy analysis of operating lignite fired thermal power plant." *Journal of Engineering Science and Technology Review* 2, no. 1 (2009): 123-130.
- [25] Zhao, Z., S. Su, N. Si, S. Hu, Y. Wang, J. Xu, L. Jiang, G. Chen, and J. Xiang. "Exergy analysis of the turbine system in a 1000 MW double reheat ultra-supercritical power plant." *Energy* 119 (2017): 540-548.
- [26] Reddy, B. V., and K. Mohamed. "Exergy analysis of a natural gas fired combined cycle power generation unit." *International Journal of Exergy* 4, no. 2 (2007): 180-196.
- [27] Srinivas, T. "Thermodynamic modelling and optimization of a dual pressure reheat combined power cycle." *Sadhana* 35, no. 5 (2010): 597-608.
- [28] Eke, M. N., D. C. Onyejekwe, O. C. Iloeje, C. I. Ezekwe, and P. U. Akpan. "Energy and exergy evaluation of a 220MW thermal power plant." *Nigerian Journal of Technology* 37, no. 1 (2018): 115-123.
- [29] Bahadori, A., and H. B. Vuthaluru. "A method for estimation of recoverable heat from blowdown systems during steam generation." *Energy* 35, no. 8 (2010): 3501-3507.
- [30] Noroozian, A., A. Mohammadi, M. Bidi, and M. H. Ahmadi. "Energy, exergy and economic analyses of a novel system to recover waste heat and water in steam power plants." *Energy conversion and management* 144 (2017): 351-360.
- [31] Rao, T. M., and S. S. Rao. "A method to improve exergetic efficiency of power plant cycle by heat pipes." *International Journal of Applied Engineering Research* 13, no. 1 (2018): 311-317.
- [32] Vandani, A. M. K., M. Bidi, and F. Ahmadi. "Exergy analysis and evolutionary optimization of boiler blowdown heat recovery in steam power plants." *Energy conversion and management* 106 (2015): 1-9.
- [33] Kaushik, S. C., V. Siva Reddy, and S. K. Tyagi. "Energy and exergy analyses of thermal power plants: A review." *Renewable and Sustainable energy reviews* 15, no. 4 (2011): 1857-1872.

- [34] Tsatsaronis G., F. Czielsa, "Thermoeconomics", in Meyer's, R. (Ed.): Encyclopedia of Physical Science and Technology, 3rd ed., Vol. 16, Academic Press (2002).
- [35] Ahmadi, G. R., and D. Toghraie. "Energy and exergy analysis of Montazeri steam power plant in Iran." *Renewable and Sustainable Energy Reviews* 56 (2016): 454-463.
- [36] Bejan, A. "Advanced Engineering Thermodynamics Wiley & Sons." *New York* (1988).
- [37] Turner WC., S. Doty, "Energy management handbook". 6th ed. GA, USA: Fairmont Press; (2007).
- [38] Bhambare, K. S., Sushanta K. Mitra, and U. N. Gaitonde. "Modeling of a coal-fired natural circulation boiler." *Journal of Energy Resources Technology* 129, no. 2 (2007): 159-167.
- [39] American Boiler Manufacturer Association (ABMA).
- [40] Changliang, L., L. Jizhen, N. Yuguang, and L. Weiping. "Nonlinear boiler model of 300 MW power unit for system dynamic performance studies." In *ISIE 2001. 2001 IEEE International Symposium on Industrial Electronics Proceedings (Cat. No. 01TH8570)*, vol. 2, pp. 1296-1300. IEEE, 2001.
- [41] Åström, K. J., and R. D. Bell. "Drum-boiler dynamics." *Automatica* 36, no. 3 (2000): 363-378.
- [42] Lotfi Zadeh, A. "Fuzzy sets." *Information and control* 8, no. 3 (1965): 338-353.